

OLYMPUS

Polarizing Microscope

BX53-P

BX3 Series

A New Standard for Polarized Light Observation



Designed to Meet Your Needs and Requirements

The Olympus BX53-P polarizing microscope provides superb performance in polarized light applications using a combination of UIS2 infinity-corrected optics and an advanced optical design. The microscope is versatile to handle observation and measuring applications in virtually any field thanks to an extended line of compatible compensators.



*Scales indicate actual size of samples

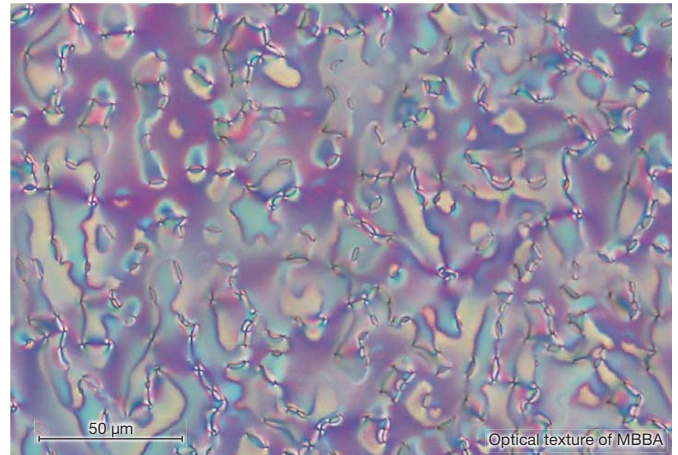

Bertrand Lens for Conoscopic and Orthoscopic Observations

With a conoscopic observation attachment, switching between orthoscopic and conoscopic observation is simple. It is focusable for viewing of clear back focal plane interference patterns. The Bertrand field stop makes it possible to obtain consistently sharp and clear conoscopic images.



Polarized light accessories

Minimal Strain Optics

The sophisticated design and manufacturing technology used in our polarized light objectives reduces internal strain to a minimum. This means a higher EF value, resulting in excellent image contrast.



Polarized light accessories

UPLFLN-P SERIES

Objectives	NA	W.D.
UPLFLN 4XP	0.13	17.0 mm
UPLFLN 10XP	0.30	10.0 mm
UPLFLN 20XP	0.50	2.1 mm
UPLFLN 40XP	0.75	0.51 mm
UPLFLN 100XOP	1.30	0.2 mm

An Extensive Range of Compensators and Wave Plates

Six different compensators are available for measurement of birefringence in rock and mineral thin sections. Measurement retardation level ranges from 0 to 20λ . For easier measurement and high image contrast, the Berek and Senarmont compensators can be used, which change the retardation level in the entire field of view.



MEASURING RANGE OF COMPENSATORS

Compensator	Measurement Range	Applications
Thick Berek (U-CTB)	0–11000 nm (20λ)	Measurement of high retardation level ($R^* > 3\lambda$), (crystals, macromolecules, fiber, etc.)
Berek (U-CBE)	0–1640 nm (3λ)	Measurement of retardation level (crystals, macromolecules, living organisms, etc.)
Senarmont Compensator (U-CSE)	0–546 nm (1λ)	Measurement of retardation level (crystals, living organisms, etc.); enhancement of image contrast (living organisms, etc.)
Brace-Koehler Compensator 1/10 λ (U-CBR1)	0–55 nm ($1/10\lambda$)	Measurement of low retardation level (living organisms, etc.)
Quartz Wedge (U-CWE2)	500–2200 nm (4λ)	Approximate measurement of retardation level (crystal, macromolecules, etc.)

*R = retardation level

For more accurate measurement, we recommend that compensators (except U-CWE2) be used together with the interference filter 45-IF546



BX53-P Conoscopic/ Orthoscopic Configuration



BX53-P Orthoscopic Configuration

BX53-P SYSTEM DIAGRAM

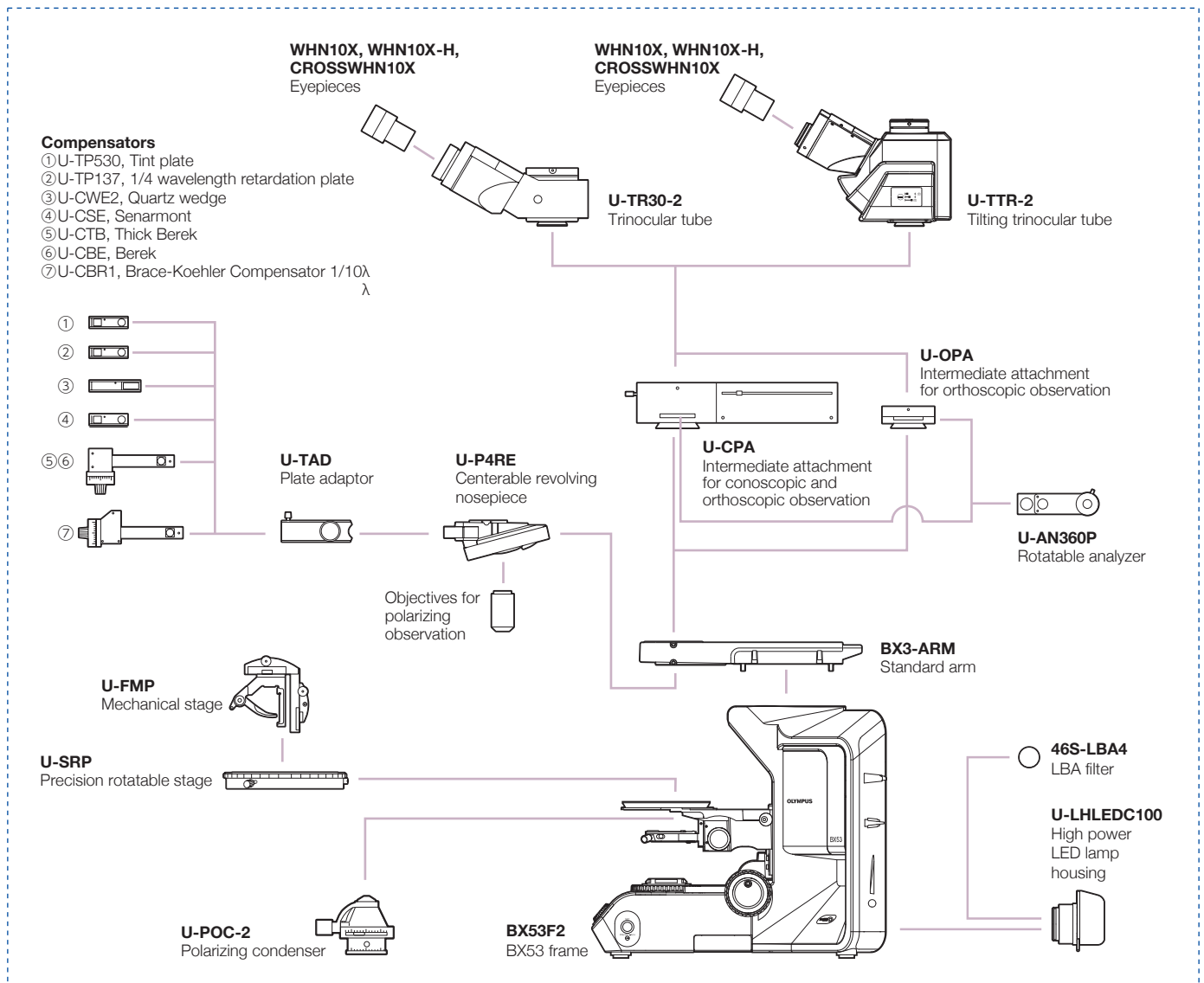

BX53-P SPECIFICATIONS

Item		Conoscopic and Orthoscopic Observation (U-CPA)	Orthoscopic Observation (U-OPA)
Polarized Light Intermediate Attachment (U-CPA or U-OPA)	FN	22	22
	Bertrand Lens	Focusable	—
	Bertrand Field Stop	ø3.4 mm Diameter (fixed)	—
	Engage or disengage the Bertrand lens changeover between orthoscopic and conoscopic observation	Position of slider ● in Position of slider ○ out	—
	Analyzer Slot	Rotatable Analyzer with Slot (U-AN360P)	
Analyzer (U-AN360P)	360° dial-rotatable Rotatable, minimum angle: 0.1°		
Revolving Centerable Nosepiece (U-P4RE)	Quadruple, centerable attachable components: 1/4 wavelength retardation plate (U-TP137), tint plate (U-TP530), and various compensators can be attached using the plate adaptor (U-TAD).		
Stage (U-SRP)	Polarizing rotatable stage with 3-point centering function. 360° rotatable, lockable in any position, 360° graduated in 1° increments (minimum retardation resolution 6', using vernier scale). 45° click stop function. Slide holder (U-SCB2) and mechanical stage (U-FMP) can be attached.		
Condenser (U-POC-2)	Achromat reduced strain condenser (U-POC-2), 360° rotatable polarizer with swing-out achromatic top-lens, click stop at position "0°" is adjustable. NA: 0.9 (top-lens in) NA: 0.18 (top-lens out) Aperture iris diaphragm: adjustable from 2 mm to 21 mm diameters.		

BX53-P DIMENSIONS

(unit: mm)

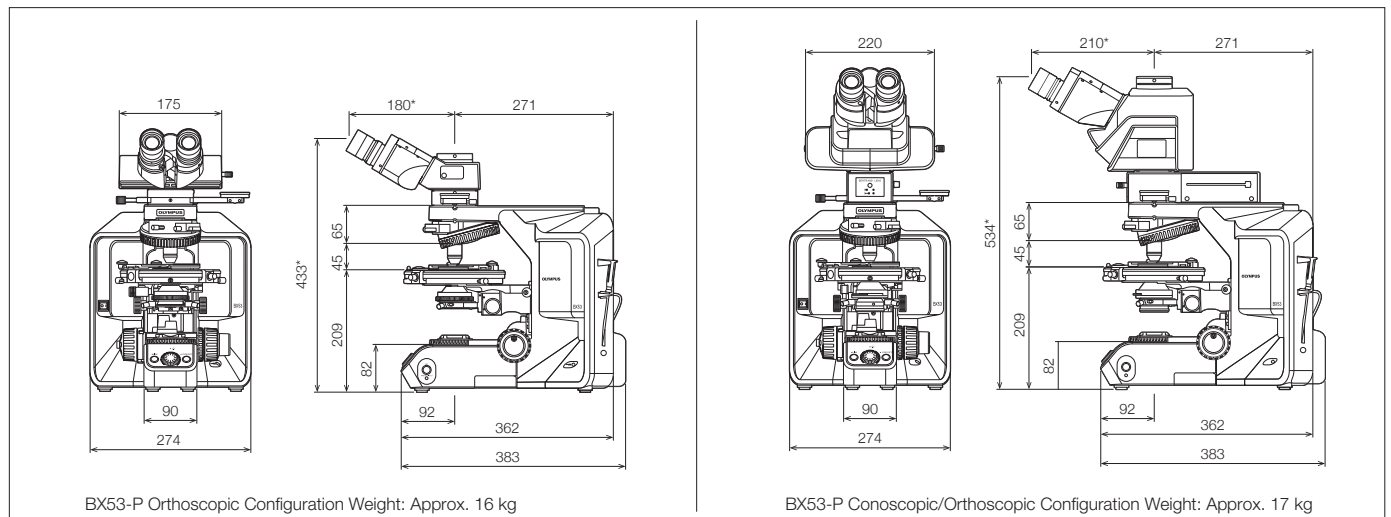

Power consumption: Approx. 24 W. Note: The length marked with an asterisk (*) may vary according to the interpupillary distance setting. Distance for figure shown is 62 mm.

